

Steilkegel-Werkzeugaufnahmen 15T
für Tsugami Dreh- Fräs- Bearbeitungszentrum
HS20M / HS20M-5AX

ISO Taper-toolholders 15T for Tsugami
drill- mill- machining centre HS20M / HS20M-5AX



Katalog Nr. 16110
Catalogue No. 16110



Typ 15T



Spannzangenfutter für Spannzangen DIN 6499 + ETS

Collet chuck for collets DIN 6499 + ETS

Rundlaufgenauigkeit Steilkegel zu Werkzeugaufnahme < 0,005
Concentricity from the taper to the holding part < 0,005

gewuchtet G 2,5 - 30.000 U/min. oder U < 1 gmm
balanced G 2,5 - 30.000 r.p.m. or U < 1 gmm

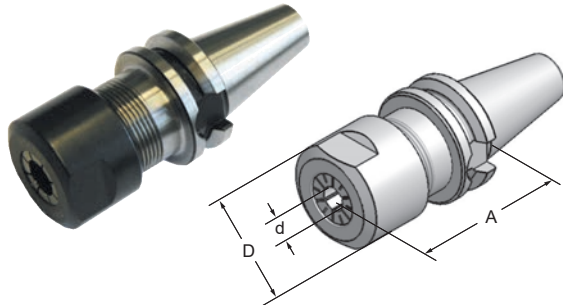

Tsugami 15T

Art.-Nr.	Typ	A	d	D
15.05.07.20	15TxER11x40	40	0,5- 7	19
15.05.07.2	15TxER11x50	50	0,5- 7	19
15.05.07.22	15TxER11x75	75	0,5- 7	19
15.05.10.20M	15TxER16mx40	40	0,5-10	25
15.05.10.20E	15TxETS16x40	40	0,5-10	25
15.05.10.22M	15TxER16mx75	75	0,5-10	25
15.05.13.20M	15TxER20mx40	40	1-13	28

Schrumpffutter

Shrinking chuck

Rundlaufgenauigkeit Steilkegel zu Werkzeugaufnahme < 0,005
Concentricity from the taper to the holding part < 0,005

gewuchtet G 2,5 - 30.000 U/min. oder U < 1 gmm
balanced G 2,5 - 30.000 r.p.m. or U < 1 gmm

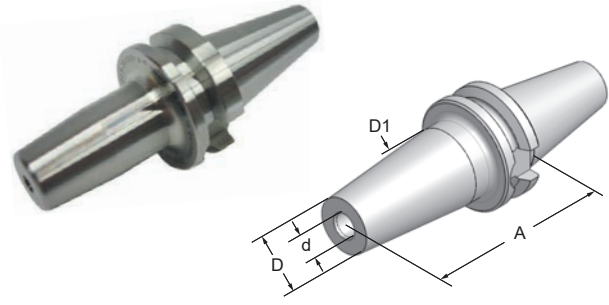

Tsugami 15T

Art.-Nr.	Typ	A	d	D	D1
15.05.03.31	15Tx03Sx50	50	3	10	14
15.05.04.31	15Tx04Sx50	50	4	10	14
15.05.05.31	15Tx05Sx50	50	5	14	19
15.05.06.31	15Tx06Sx50	50	6	14	19
15.05.08.31	15Tx08Sx50	50	8	14	19
15.05.10.31	15Tx10Sx40	40	10	15	19

Bohrstangenhalter Form E2

Boring bar holder form E2

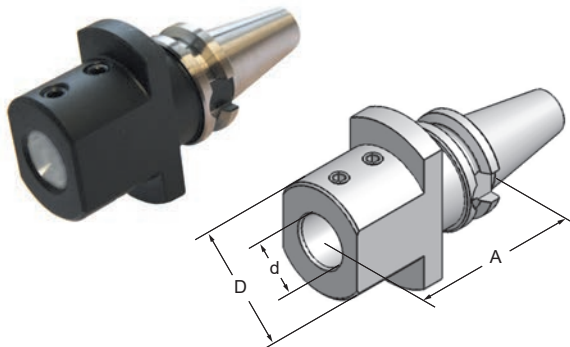

Tsugami 15T

Art.-Nr.	Typ	A	d	D
15.05.06.290	15Txø06x48	48	6	24
15.05.08.290	15Txø08x48	48	8	24
15.05.10.290	15Txø10x48	48	10	26
15.05.12.290	15Txø12x48	48	12	30
15.05.14.290	15Txø14x48	48	14	30
15.05.16.290	15Txø16x48	48	16	32

Axial-Werkzeughalter Form C4

Axial toolholder form C4

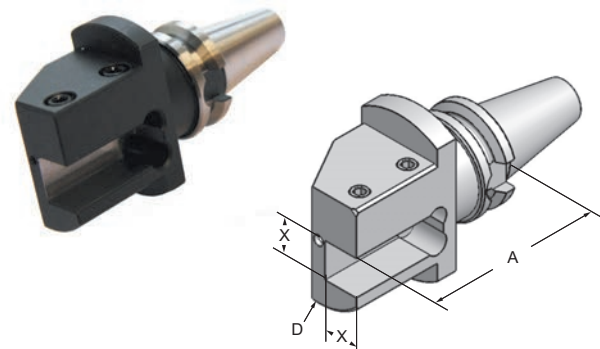

Tsugami 15T

Art.-Nr.	Typ	A	X	D
15.05.10.040	15Tx10/10x52	52	10	36

Anzugsbolzen

Retention knob

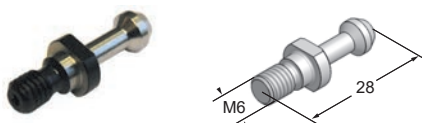

Art.-Nr.	Typ
15.06.4	BT15x45°

Spannschlüssel

Key



Art.-Nr.	SW	für Spannmutter
911180	17	ER11
916162	22	ER16m
916163	24	ETS16
920160	E 20 mini	ER20m